

CONFIGURATION DETAILS OF
UNDIMENSIONED FEATURES
MAY VARY

REVISIONS			
REV	DESCRIPTION	DATE	APPROVED
A0	INITIAL RELEASE	2023.01.03	

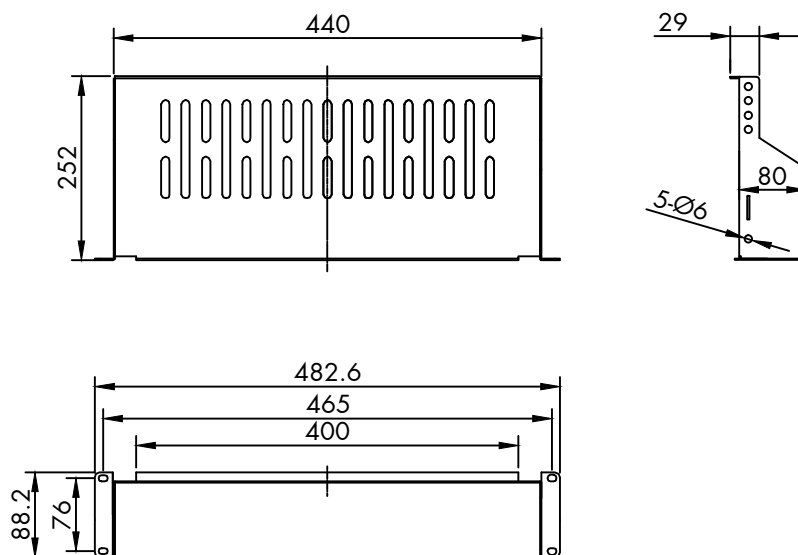

Accessory:
Screw /cage nut/ black washer ----M6*16 4sets
RoHS2.0(2011/65/EU) AND (2015/863/EU) WITH REACH COMPLIANT

NAME	VALUE 19" Cantilever Shelf 2UH, < 15 kg D: 250 mm		
ITEM NO.	26.99.0405		
SECOMP	MAPE	TOLERANCE	
		X.	±1.00
		X.X	±0.50
	DRAW BY	SCALE	MM
		PAGE	1/1

NO.	PART NAME	DESCRIPTION	QUANTITY	REMARKS
①	METAL	1.2MM/SPCC WITH BLACK COLOUR PAINTING	1	